



100 West Washington Street, Suite 1101 | Hagerstown, MD 21740-4735 | P: 240.313.2200 | F: 240.313.2201  
WWW.WASHCO-MD.NET

## BOARD OF COUNTY COMMISSIONERS

November 9, 2021

### OPEN SESSION AGENDA

*The Board of County Commissioners will be meeting with the Washington County Delegation at 10:00 am at Hagerstown Community College as part of the Delegation's Pre-Legislative Forum.*

- 11:30 AM      MOMENT OF SILENCE AND PLEDGE OF ALLEGIANCE  
                  CALL TO ORDER, *President Jeffrey A. Cline*  
                  APPROVAL OF MINUTES: *November 2, 2021*
- 11:35 AM      COMMISSIONERS' REPORTS AND COMMENTS
- 11:40 AM      STAFF COMMENTS
- 11:45 AM      CITIZEN PARTICIPATION
- 11:50 AM      PRESENTATION: WASHINGTON COUNTY CELEBRATES VETERANS DAY  
                  *By Public Relations and Washington County Employees*
- 12:00 PM      PRESENTATION: 100<sup>TH</sup> ANNIVERSARY OF THE FOUR "VAGABONDS" AT CAMP  
                  HARDING  
                  *By Public Relations and Krista Hart, County Clerk*
- 12:10 PM      CONTINGENCY REQUEST FROM THE TOWN OF CLEAR SPRING  
                  *Juanita Grimm, Clerk, Town of Clear Spring*
- 12:15 PM      MARYLAND AGRICULTURAL LAND PRESERVATION PROGRAM (MALPP) 60/40  
                  MATCH FOR FY 2022  
                  *Chris Boggs, Rural Preservation Administrator, Planning and Zoning*
- 12:20 PM      RETENTION OF GOVERNMENT RELATIONS CONSULTANT AND LOBBYIST  
                  *Kirk C. Downey, County Attorney*
- 12:25 PM      CLOSED SESSION - *To discuss the appointment, employment, assignment, promotion, discipline, demotion, compensation, removal, resignation, or performance evaluation of appointees, employees, or officials over whom this public body has jurisdiction; or any other personnel matter that affects one or more specific individuals & To consider the acquisition of real property for a public purpose and matters directly related thereto.*
- 12:50 PM      RECONVENE IN OPEN SESSION
- 12:55 PM      ADJOURNMENT



Agenda Report Form

Open Session Item

**SUBJECT:** Video Presentation: Washington County Celebrates Veterans Day

**PRESENTATION DATE:** November 9, 2021

**PRESENTATION BY:** Public Relations Team and County Staff

**RECOMMENDED MOTION:** N/A

Video Presentation displayed by our Public Relations team.



Open Session Item

**SUBJECT:** Video Presentation: 100<sup>th</sup> Anniversary of the Four “Vagabonds” visit to Camp Harding

**PRESENTATION DATE:** November 9, 2021

**PRESENTATION BY:** Public Relations Team and County Clerk

**RECOMMENDED MOTION:** N/A

Video Presentation displayed by our Public Relations team and the County Clerk.



## Agenda Report Form

---

### Open Session Item

**SUBJECT:** Funding for Veterans Memorial Flag Poles

**PRESENTATION DATE:** November 9, 2021

**PRESENTATION BY:** Juanita Grimm, Town Clerk, Town of Clear Spring

**RECOMMENDED MOTION:** To approve funding request for the Town of Clear Spring in the amount of \$20,000.00 from the Commissioner contingency fund.

**REPORT-IN-BRIEF:** Veterans banners are currently displayed on the decorative light poles on Cumberland Street however, there are more banners than poles. Displaying the banners around the Veteran's Memorial would be an appropriate location and all the banners could be displayed at one time.

**DISCUSSION:**

**FISCAL IMPACT:** \$20,000.00

**CONCURRENCES:** N/A

**ALTERNATIVES:** N/A

**ATTACHMENTS:** Letter of Request dated July 28, 2020  
HADCO pole drawing  
Summary of cost estimates  
Banner pole quote from Deporter, Dominick & Associates  
Banner Bracket Hardware Price  
G.A. Sigler Masonry cost estimate

Paul D. Hose, Jr.  
Mayor

Steven L. Blickenstaff  
Vice Mayor

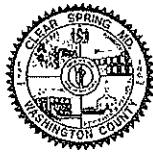

**Town of Clear Spring**

P. O. Box 104 • Clear Spring, Maryland 21722-0104  
Phone: 301-842-2252 • Fax: 301-842-2920

Council  
Theodore R. Hovermale  
Carol E. Hovermale  
Michael W. Johnson

July 28, 2020

Washington County Board of County Commissioners  
100 West Washington Street  
Hagerstown, MD 21740

Dear Commissioners:

The Clear Spring Mayor and Council, Clear Spring American Legion and the Veterans Banner Committee would like to thank you for listening to our proposal to install poles around the Veterans Memorial located at the Clear Spring Park to display the Veterans banners. The banners are currently displayed on the decorative light poles on Cumberland Street however, we have more banners than poles. We feel the military banners displayed around the Veterans Memorial would be an appropriate location.

At this time we would like to request funding from the contingency fund of the County to help us establish this task. Estimated cost of the project is \$20,000.00. Any consideration would be greatly appreciated.

If you have any questions, please feel free to contact me.

Sincerely,

Juanita K. Grimm  
Town Clerk

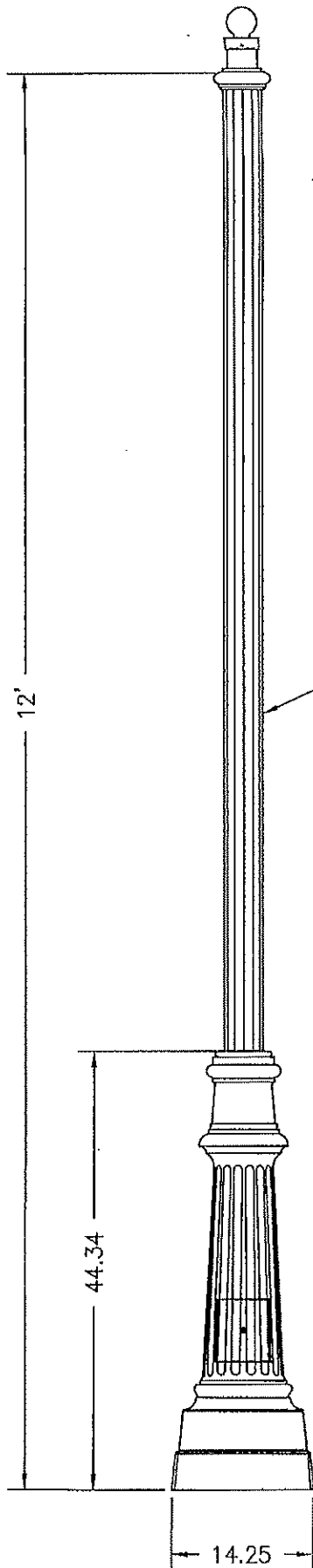

POLE ASSEMBLY: MODIFIED,  
 4" ROUND, STRAIGHT FLUTED  
 ALUMINUM W/ 3" O.D. TENON,  
 0.125" WALL THICKNESS,  
 MODIFIED W/ POLE BALL CAP  
 HELD IN PLACE W/ (3) SET  
 SCREWS AT 120°, CAST ALUMINUM  
 BASE W/ ACCESS DOOR

BASE TEMPLATE:  
 #T01000863

Ordering Guide

SP6615B: POLE ASSMEBLY  
 Modifications: Pole ball cap.

COLOR:  
 BLACK

PRODUCT APPROVALS	
HADCO	JLN
CUSTOMER	
<p><b>CONFIDENTIAL:</b>          This drawing is confidential and proprietary to Hadco and may not be reproduced without the express written consent of Hadco. Any use hereof or of any of the information or detail herein shall be for the sole benefit of Hadco.</p> <p><b>NOTICE:</b>          This drawing is for reference only. Check for latest revision prior to ordering.</p>	
	
100 Craftway Drive Littlestown, Pa 17340 Phone 800-937-5483 Fax 717-359-0618 www.signify.com	
JOB NAME:	
City of Clear Spring, MD	
DRAWN BY:	
H. Kuhn	
SCALE:	DATE:
1:16	03/21/19
DRAWING NUMBER:	
S6615-DWG02	
REP:	
DePorter, Dominick	
REV: A	PCN: 19-003
BY: .	DATE: .

Flag Poles Clear Spring Cost Estimates

Deporter, Cominick & Associates	\$41,250.00	Poles 30
Street Light Pole Banner Brackets	\$1,920.00	Brackets 30
G.A. Sigler Masonry	\$ 3,000.00	Concrete Bases
	\$46,170.00	



**DEPORTER, DOMINICK & ASSOCIATES**

<b>To:</b> TOWN OF CLEAR SPRING DEPORTER DOMINICK & ASSOCIATES	<b>Job Name:</b> TOWN OF CLEAR SPRING BANNER POLES
<b>Entry Date:</b> 11/5/2021	

Qty	Type	Mfg	Description	Unit Price	Extd Price
30	POLES	SIG	SP6615B-12A	\$1,375.00	\$41,250.00
<b>TOTAL:</b>					<b>\$41,250.00</b>

MFG Code	F.O.B	TERMS	Lead Time
SIG	/ FREIGHT ALLOWED ON ORDERS OF \$1,000 OR MORE	SHIP ORDER COMPLETE	

**Prices firm for entry by:** \_\_\_\_\_ **Shipment by:** \_\_\_\_\_

PRICING VALID FOR 30-DAYS, UNLESS OTHERWISE NOTED

ORDER CANCELATIONS MAY RESULT IN PENALTIES FOR PART OR ALL OF ORDER VALUE

CONTROL NODES OR PHOTOCELLS NOT INCLUDED

LEAD TIMES ARE ESTIMATES AND ARE NOT GUARANTEED

FREIGHT NOT INCLUDED, UNLESS OTHERWISE NOTED

APPROVED OR SIGNED COPIES OF SUBMITTALS REQUIRED TO RELEASE ORDER

DDA IS NOT RESPONSIBLE FOR MEETING SPECIFICATIONS OR SPECIAL CONDITIONS NOT FURNISHED BY DISTRIBUTOR AT TIME OF QUOTE REQUEST

CHANGES IN QUANTITIES MAY REQUIRE A RE-QUOTE

ADDITIONAL COSTS FOR ENGINEERING OR CALCULATIONS NOT INCLUDED UNLESS OTHERWISE NOTED

SALES TAX IS NOT INCLUDED IN QUOTE TOTAL

Printed: 11/05/21 10:20:27 Per: Henry Wilson Email: henry@ddallc.com



Hello  
Select your address

All banner pole mount for light post

Hello, Sign In  
Account & Lists Returns  
& Orders

0

All Best Sellers Customer Service Prime New Releases Books Pharmacy Registry

Get a jump on joy, shop gifts now

Office Products Office Deals School Supplies Printers, Ink & Toner Projectors

38,210

Back to results

Sponsored



Click image to open expanded view

### Signworld 30" Street Light Pole Banner Bracket Hardware

Brand: Signworld

18 ratings | 6 answered questions

Price: \$32.00

Material Aluminum  
Color Gray, white pole  
Brand Signworld

#### About this item

- For banners up to 30" wide each side, Banner NOT included.
- 3/4" fiberglass rods with end caps to secure your banner and reduce wind load on banner
- Aluminum Cast Base made to fit square, round, or multi sided poles.
- Stainless steel bands and aluminum base will not rust while keeping your banner secured.

Compare with similar items

\$32.00

FREE delivery: Nov 8 - 12

Select delivery location

In Stock.

Qty: 1

Add to Cart

Buy Now

Secure transaction

Ships from Signworld America Inc.  
Sold by Signworld America Inc.

Return policy: Returnable until Jan 31, 2022

1-Click ordering is not available for this item.

Add to List

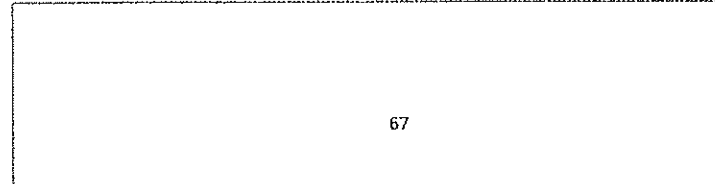

Sponsored

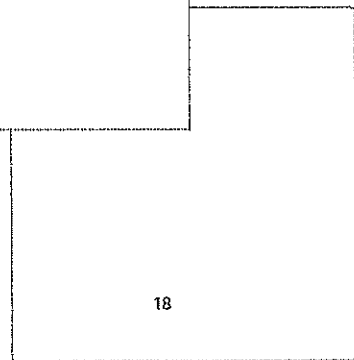

Sponsored

#### Frequently bought together



+



Total price: \$63.00

Add both to Cart

- This item: Signworld 30" Street Light Pole Banner Bracket Hardware \$32.00
- Signworld 24" Street Light Pole Banner Bracket Hardware \$31.00

4 stars and above

Sponsored

Page 1 of 6

G.A. Sigler Masonry & Construction, Inc.  
11305 Gift Road  
Clear Spring, MD 21722  
301-812-2727

COST ESTIMATE

Town of Clear Spring  
P.O. Box 104  
Clear Spring, MD 21722

Cost to install concrete bases for banner poles at Clear Spring Park around Veterans Memorial.

\$3,000.00



## Agenda Report Form

### Open Session Item

**SUBJECT:** Maryland Agricultural Land Preservation Program (MALPP) 60/40 Match for FY 2022

**PRESENTATION DATE:** November 9, 2021

**PRESENTATION BY:** Chris Boggs, Rural Preservation Administrator, Planning and Zoning

**RECOMMENDED MOTION:** Move to approve a \$700,000.00 commitment from the County Agricultural Transfer Tax, and State Agricultural Transfer Tax to the 60/40 match component of the MALPP easement program for FY 2022 Cycle.

**REPORT-IN-BRIEF:** Each year MALPP asks counties if they want to obligate funds to the 60/40 match portion of the Land Preservation Easement Program. Land Preservation staff is recommending that Washington County designate \$700,000 as its 40% local match in order to receive the 60% State match of \$1,050,000.

The commitment requested today will result in total funding of about \$2,650,000 for easement purchases in FY 22 (including approximately \$900,000 of general allotment funds that all counties receive). Agricultural Transfer Taxes collected each year are restricted for use in preservation programs and are not General Fund dollars.

**DISCUSSION:** For clarity sake, State funding contributions to the Ag Preservation Program result from the following distributions. The entire MALPP fund is divided in half. One half is divided equally among all Maryland counties which will result in an FY 2022 “General Allotment” of approximately \$900,000 for each County. The remaining half is divided among only those Counties that make local commitments to the 60/40 matching program and is used for the State’s 60% contribution. The County may add General Funds dollars to its 40% match which would result in additional matching funds from the State and an increase in the total amount available for easement purchases.

**FISCAL IMPACT:** This 60/40 match commitment and General Allotment money results in funds for land preservation easement purchases on 4 farms. There are no General Funds involved. \$400,000 comes from the County’s Agricultural Transfer Tax; and \$300,000 comes from the State Agricultural Transfer Tax.

**CONCURRENCES:** The Agricultural Land Preservation Advisory Board has endorsed the use of the above funding source for the 60/40 match.

**ALTERNATIVES:** Make no commitment to the matching program; or commit further funding to the 60/40 match through the use of County General Funds.

**ATTACHMENTS:** N/A

**AUDIO/VISUAL NEEDS:** N/A



## Agenda Report Form

### Open Session Item

**SUBJECT:** Retention of Government Relations Consultant and Lobbyist

**PRESENTATION DATE:** November 9, 2021

**PRESENTATION BY:** Kirk C. Downey, County Attorney

**RECOMMENDED MOTION:** I move to retain Bruce C. Bereano as the County's government relations consultant and lobbyist for 2022 upon the terms set forth in the proposed retainer letter dated October 22, 2021.

**REPORT-IN-BRIEF:** To consider the retention of government relations consulting and lobbying services.

**DISCUSSION:** Bruce C. Bereano has served the Board of County Commissioners as its government relations consultant and lobbyist for the past five years. Mr. Bereano has offered to again serve in this role for the 2022 General Assembly session and through October 31, 2022, for a fixed engagement fee of \$10,000. Mr. Bereano's services include monitoring legislation; arranging and attending meetings with legislative and executive branch officials; providing counsel and advice concerning political and legislative matters; and delivering other customary government relations and lobbying services. Mr. Bereano's retention as the County's government relations consultant and lobbyist would provide the County with an ongoing presence and voice in Annapolis, as Mr. Bereano regularly attends delegation meetings, bill hearings, and other political events.

**FISCAL IMPACT:** \$10,000

**CONCURRENCES:** N/A

**ALTERNATIVES:** N/A

**ATTACHMENTS:** Proposed retainer letter.

**AUDIO/VISUAL NEEDS:**

THE OFFICE OF  
**BRUCE C. BEREANO**  
191 DUKE OF GLOUCESTER STREET  
ANNAPOLIS, MARYLAND 21401  
410-267-0410 ANNAPOLIS AREA  
410-269-5330 BALTIMORE AREA  
301-261-1100 WASHINGTON D.C. AREA  
410-267-0177 FAX

October 22, 2021

The Honorable Jeff Cline  
President  
Washington County Commissioners  
100 West Washington Street, Room 226  
Hagerstown, Maryland 21740

Dear President Cline:

In preparation for the upcoming 2022 Session of the Maryland General Assembly which convenes January 12, 2022, and for calendar year 2022, I write to propose to the Washington County Commissioners to represent and serve the Commissioners as their government relations consultant and lobbyist in Annapolis during the upcoming 2022 session of the General Assembly and before the Executive Branch of State Government. The term of my representation would be the calendar year of 2022.

I have appreciated and enjoyed representing the County for the past 5 years and I would be happy and willing to continue to act in such a capacity for the proposed same fee of \$10,000 plus reimbursement for any reasonable and necessary expenses such as mileage and travel, lobbying registration fee, duplication costs, etc.

The scope and nature of the government relations and lobbying services I would provide the Washington County Commissioners would include the following:

1. Making available the depth and breadth of my relationships and network, and experience developed over the past 50 years in government and politics in Maryland;
2. Provide government and political strategic advice and counsel concerning relationships with government elected and appointed officials;
3. Arrange and attend meetings for the County Commissioners with key legislative and executive branch officials;
4. Advise and inform the County Commissioners of particular events and functions which are good networking opportunities and ways to increase the presence and involvement in relationship development for the County;

5. Focus my efforts and attention on areas of interest and agenda of the County with the legislature and executive branches of government as requested;
6. Meet and work with Washington County Commissioners as and when requested concerning issues, problems and assistance I can render with State government officials, agencies;
7. Register as a lobbyist for the Washington County Commissioners as required by law and comply with all legal requirements;
8. Customary and usual professional lobbying and government relations activities and efforts on behalf of the Washington County Commissioners;
9. Assist in advocating and representing Washington County on legislation as indicated;
10. Keep the Washington County Commissioners fully informed of my activities and efforts on their behalf and maintain current and clear communications in this regard;
11. Assist in securing meetings with key government appointed and elected officials and attend any and all such meetings which are arranged;
12. Provide any other and further services and functions as requested and desired by the County Commissioners relative to my role and function;
13. Attend all Washington County Delegation meetings during the legislative session and work in harmony and coordination with the Washington County legislative Delegation and be of assistance;
14. Work closely with the Washington County Commissioners on their legislative agenda and priorities for the 2022 legislative session;

It is also understood and agreed that you hereby certify and declare that Bruce C. Bereano hereby is authorized to act as a lobbyist and government relations representative on behalf of the Washington County Commissioners for the time period of November 1, 2021 through October 31, 2022 as to matters between them.

I would very much appreciate the opportunity to work with the Washington County Commissioners, and you can be assured of my fullest professional and dedicated services.

Please feel free to discuss this matter further with me or let me know any questions you or the other Commissioners may have. I of course am willing and available to meet with the County Commissioners to further discuss and decide this matter. If this

arrangement is agreeable and acceptable please sign and return to me one of the enclosed copies for my files. Thanking you in advance for your consideration and time, I am

Sincerely,

  
Bruce C. Bereano

Intending to be legally bound, the parties have duly executed this Agreement below:

**Washington County Commissioners**

\_\_\_\_\_  
By:

The Honorable Jeff Cline  
President  
Washington County Commissioners  
100 West Washington Street, Room 226  
Hagerstown, Maryland 21740

Date: \_\_\_\_\_

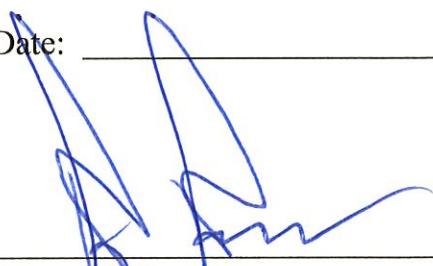
  
\_\_\_\_\_  
**Bruce C. Bereano**  
191 Duke of Gloucester Street  
Annapolis, Maryland 21401

Date: \_\_\_\_\_

11/2/21