



DIVISION OF
PLAN REVIEW & PERMITTING

**UTILITY PERMIT
SPECIFICATIONS AND PERMIT APPLICATION**

Application Fee: \$25.00 (Make check payable to: Washington County Treasurer).

Bond: A Utility Installation Bond is required. The standard amount is \$2,500 and subject to increase depending on the scope of work as determined by the Washington County Division of Plan Review & Permitting.

Drawings: All work shall be done in accordance with the Standards and Specifications for Public Works Construction, latest edition, and with drawings approved by the Division of Plan Review & Permitting as part of this permit issuance.

***Open Cut/Trenching:** Under NO circumstances will open cut or trenching be permitted within the County right-of-way without the express written permission of the Division of Construction. Any open cut or trenching must be patched in accordance with DPW Standard Detail UP-1.01, the specifications listed below, and Permittee's responsibility under the Washington County Division of Public Works Policy for Utility Construction within the County Public Right-of-Way (DPW-2).

Drainage: Existing drainage along and within a County Right-of-Way shall not be disturbed. The Permittee will assume the responsibility for damages to adjoining property which may be the result of any changes to the present drainage conditions and agrees to hold Washington County harmless from any action resulting from changes and hereby agrees to indemnify Washington County against any and all claims resulting from this activity.

Maintenance of Traffic: Permittee shall comply with all applicable provisions of the Maryland Manual of Uniform Traffic Control Devices, Streets and Highways, latest edition.

Pedestrians: Provisions must be made for pedestrians to utilize the area without entering onto the pavement, where applicable.

Motor Vehicles: Normal traffic along a County Right-of-Way shall be maintained at all times, using signs, flashers, barricades, flagmen, etc. All required signs shall be placed prior to construction or placement of any equipment or materials on site.

Use of Explosives: Use of explosives shall be permitted only where necessary and as such, a minimum charge shall be used. The Permittee shall comply with applicable State regulations.

Curbing/Sidewalk: Permittee shall maintain sidewalk, curbing, mailboxes, pavement and drainage systems in the vicinity of the work area. Any damage to existing curbing and sidewalks shall be repaired or replaced to the satisfaction of the Washington County Division of Construction at the sole expense of the Permittee.

Miscellaneous:

- a. Forty-eight (48) hours prior to beginning construction, the Permittee must notify the Division of Construction of the intent to begin the proposed work. Failure to make the appropriate notification shall be just cause to issue a "stop work order" until the appropriate inspections can be arranged
- b. The Permittee must contact Miss-Utility at 1-800-257-7777, a minimum of forty-eight (48) hours prior to beginning any work. No obstruction shall be placed on or within a Washington County right-of-way without the written permission of the Division of Construction, or its duly authorized agent. Violators shall be liable to prosecution for committing a misdemeanor.
- c. All open cut trenches and excavations in the paved section of roadway must be backfilled and capped with bituminous concrete cold mix or steel-plated at the end of the work day. If an open cut area is intended to be open for five (5) or more calendar days, the open cut trench shall be separated for moving traffic by concrete barriers or filled to within two (2) inches of the adjacent pavement surface throughout its entire length. Whenever concrete barriers are used to protect a work area, a Division of Construction approved MOT plan is required.
- d. All mud and debris tracked and/or spilled on the County road shall be removed promptly by the Permittee to eliminate potential hazards. Permittee shall keep the adjacent and adjoining roadways clean and free of soil, dirt and other debris at all times during the construction.
- e. Pads must be used on all backhoe outriggers. No equipment with cleat wheels or tracks is permitted on the existing paved roadway surface. Any damage to existing pavements caused by cleats or tracks shall be repaired by the Permittee.
- f. The Permittee and their agents shall wear reflective safety vests on the job site at all times. When the MOSH/OSHA regulations require the creation of an excavation safety plan, the plan shall be submitted with and form a part of the supporting documentation for the application.
- g. The Permittee is responsible for being familiar with the limits of the County right-of-way. It is the responsibility of the Permittee to make his agent or contractor familiar with the terms of the permit and this application.
- h. Starting of work within the County right-of-way, or any occupancy thereof, including ingress and egress, by the Permittee and/or their agents, constitutes full acceptance of all the terms of the permit and this application. Failure to comply with any of the terms of the permit constitutes a violation of the entire permit and may result in the termination thereof and denial of access until such time as the terms are complied with. Failure to comply may also result in the County making repairs at Permittee's expense, or by the County taking action on the Utility Installation Bond.
- i. All materials used for utility construction within the public right-of-way shall conform to the Standards and Specifications, MDOT - SHA, latest edition and the Standards and Specifications for Public Works Construction, Washington County, MD, latest edition.
- j. Permittee shall replace/install or compensate the County for any permanent traffic control markings damaged by the work and/or repairs to traffic signals/detection systems.
- k. Permittee shall maintain accessibility to any fire hydrants in the vicinity of the work area during construction.
- l. Permittee shall maintain accessibility to any driveway, commercial or private, in the vicinity of the work area.
- m. This permit will expire six (6) months from the date of permit issuance. Failure to complete the work within the specified time frame will be just cause to require the Permittee to reapply.
- n. No work on holidays and weekends shall occur unless an exception is granted in writing by the Division of Construction.

Additional Provisions: Additional provisions may apply. All work shall be done in accordance with the latest adopted edition of the Washington County Standards and Specifications for Public Works Construction, the Washington County Division of Public Works Policy for Utility Construction within the County Public Right-of-Way (DPW-2), and with the engineering drawings approved by the Division of Plan Review & Permitting as part of this permit issuance.

Inspection: All work shall be subject to inspection by the Washington County Division of Construction.

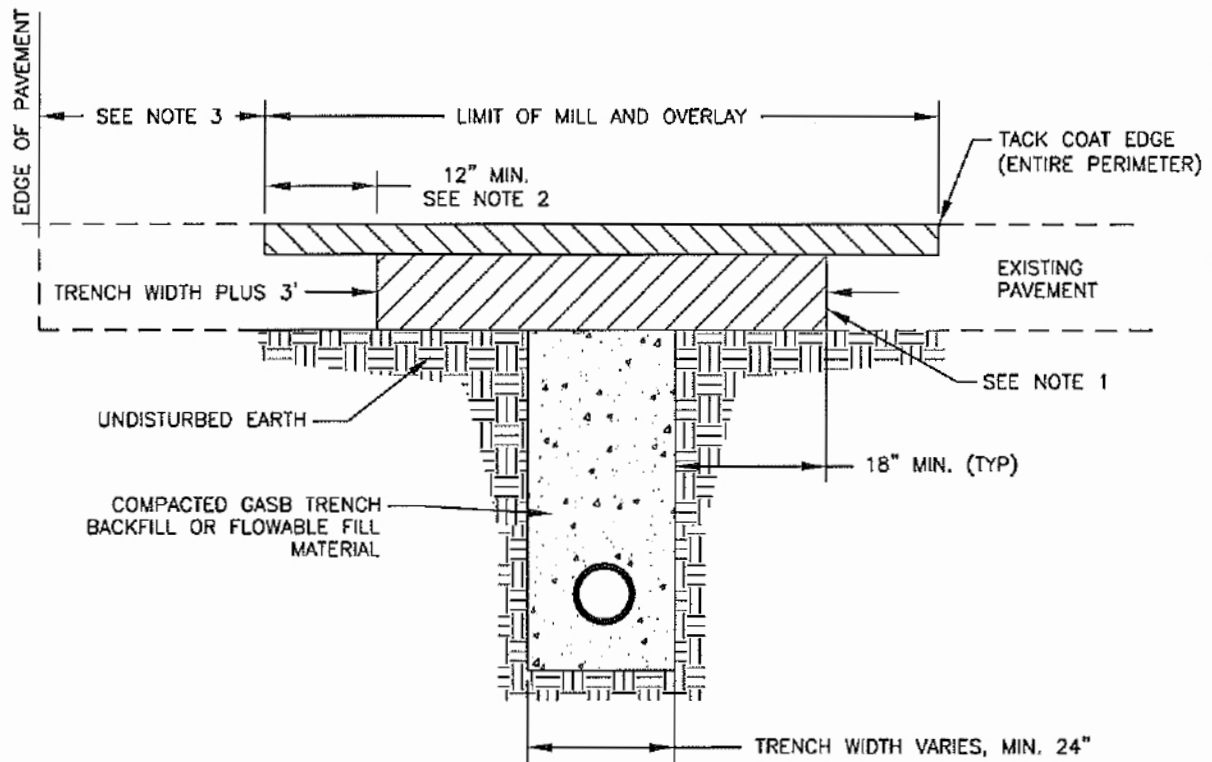

1. Existing pavement shall be milled or saw cut full depth where the limits of mill and overlay meet existing pavement.
2. For longitudinal and transverse cuts, the limits of the perimeter mill and overlay shall extend a minimum of 12" beyond the full depth patch boundary.
3. When the distance the edge of existing pavement to the edge of new asphalt base is 3 feet or less, the existing pavement shall be removed and replaced to the edge of existing pavement.
4. For longitudinal trenches, when the width of the limit of mill and overlay exceeds 50% of the total roadway width, the limit of mill and overlay shall be widened to the full width of the road, edge of pavement to edge of pavement.
5. All milling shall be a minimum of 2" in depth.
6. Hot mix asphalt (HMA) surface shall be placed to a depth equal to the depth of existing surface or 2" minimum, whichever is greater. HMA base shall be a depth equal to the depth of existing base or 6", whichever is greater. All HMA shall be compacted to an in-place density of 92 to 97 percent of the maximum specific gravity.
7. Trench backfill beneath the pavement layer shall be compacted graded aggregate subbase (GASB) to 95 percent of the maximum dry density per AASHTO T-99. Prior and during compaction, moisture of fill material shall be maintained within 2% of optimum. The fill shall be placed and compacted in horizontal layers not to exceed 8" in thickness (loose). GASB shall conform to the requirements of the latest edition of MD SHA Standards and Specifications for Construction and Materials. Flowable fill material may also be used when the depth of fill is < 5 feet and advanced approval is obtained by the Division of Public Works.
8. All compaction work shall be performed using equipment such as sheepfoot rollers or pneumatic and/or vibratory plate type compaction equipment. Backfill material shall be placed evenly structures and shall be free of boulders, frozen lumps or foreign/organic matter that could cause hard spots or decompose creating voids.
9. Where cave-ins under existing asphalt pavement occur, the existing pavement shall be saw-cut 18" beyond the limit of the cave-in. The requirements of note 3 shall be enforced as the trench boundary expands.
10. The Division of Public Works may require an independent testing lab to confirm compaction performance.

Revised _____ Revised _____ Approved _____	Washington County, MD Division of Public Works	UTILITY PATCH IN FLEXIBLE ASPHALT PAVEMENT	Detail UP-1.01
Approved: _____ Director of Public Works			



UTILITY PERMIT APPLICATION

Utility Installation Permit is required for any work performed on a County Road or Right-of-Way

Job Location/Subdivision Name:
Owner's Name:
Applicant/Utility Company Name: Phone:
Address:
Contractor's Name: Phone:
Address:
Contact Person:

Proposed Work (attach a drawing showing location and extent of work)

Description of Work:

Scope of Work

Requested Method of Installation:
Open Cut _____ Bore _____ Trench _____
Duration of Work: _____ Calendar Days
Anticipated Starting Date: _____

No. of Linear Feet: _____
No. of Open Cuts: _____
Sizes of Cuts: _____
No. of Test Pits: _____
No. of Road Bores: _____
No. of Services: _____
Other: _____

Applicant's Acknowledgment: The information I have provided on this application is true and correct to the best of my knowledge. I have ready and fully understand the requirements of the attached Utility Permit Specifications and the latest adopted edition of the Washington County Standards and County Specifications for Public Works Construction, the Washington County Division of Public Works Policy for Utility Construction within the Public right-of-Way (DPW-2). All work shall be done in accordance with the latest adopted edition of the Washington County Standards and Specifications for Public Works Construction, the Washington County Division of Public Works Policy for Utility Construction within the County Public right-of-Way (DPW-2), and in accordance with the engineering drawings approved by the Division of Plan Review as part of this permit issuance. I will notify the Washington County Division of Construction (240-313-2460) 24 hours in advance of starting any work covered under the permit.

Applicant's Signature _____

Date _____