

The "Swimming Pool" Triangle



**SWIMMING POOL PERMITS  
ARE  
ABOUT  
HEALTH AND SAFETY**



**WASHINGTON COUNTY  
SWIMMING POOL BOOKLET**

Swimming Pool Booklet  
Washington County, Maryland

Published 2004  
Revised 03/10/05  
Revised 03/31/06  
Revised 03/08/10  
Revised 10/05/10

Department of Permits & Inspections  
80 West Baltimore Street  
Hagerstown, Maryland 21740  
Phone No: 240-313-2460  
Fax: 240-313-2461  
TDD Dial: 711

## **REQUIREMENTS FOR SWIMMING POOL BOOKLET**

### **1. Where to apply for pool permit?**

The owner or his authorized representative must make application in person at:

Department of Permits & Inspections  
80 West Baltimore Street  
Hagerstown, Maryland 21740  
Phone No: 240-313-2460

### **2. Information needed to apply for pool permit.**

1. Owner's name addresses and phone number.
2. Contractor's or pool installer's name, address and Maryland Home Improvement License Number.
3. Address of the property.
4. Type of pool (in-ground or aboveground).
5. Size and depth of pool.
6. Location of pool shown on plot plan.
  - a. Front, side and rear yard distance to pool.
  - b. Distances from other improvements on property- house, garage, septic system, well, as applicable.
7. Verification that the pool barrier will be installed prior to the final building inspection.
8. Water source- private well or city water.
9. Sewage source- private septic or public sewer.

### **3. Permit fees.**

**Building:** The building permit fee is \$155.00 for above ground pools or \$205.00 for in-ground pools (Application/Technology Fee included).

**Electrical:** The electrical fee is \$180.00. (Application/Technology Fee included)

- All fees are non-refundable and subject to change.

All code references are from the 2009 IRC, 2009 ICCEC Administrative Provisions and the 2008 NEC.

If you have any questions, please do not hesitate to contact the Department of Permits & Inspections at 240-313-2460 between 7:30 a.m. and 4:30 p.m., Monday through Friday.

## **NOTES**

## Inspections Required

After the permit is approved and construction has begun, the owner or his authorized representative shall be responsible for requesting the required inspections, using the IVR System (Interactive Voice Response System) at 240-313-2488. The proper phases of construction with the Department of Permits & Inspections are as follows.

<u>Phase Of Construction</u>	<u>IVR Inspection Code</u>	<u>Work To Be Inspected</u>
Pool location; stake excavation (All Types of Pools).	200 Setbacks	Front, side, & rear clearances; over head wire clearance; Temporary barrier is in place.
Sidewalls set for In-ground pools.	300 Footer	Sidewalls set and bottoms are pinned ready for concrete.
After reinforcing Steel is in place and before concrete.	1100 Bonding/Steel	Proper bonding of steel, equipment, and light fixtures.
Under ground electrical conduit.	390 Underground Electrical	Depth of all of the electrical conduit.
Final Inspection.  Electrical work Complete.	800 Final Electrical	Bonding & GFI protection is in place & electrical work is complete. Verify permanent barrier &
Building work Complete.	830 Final Building	vacuum breaker are in place.

**Note:** The Final Electrical and Final Building inspections must be scheduled for the same day. A Use & Occupancy CANNOT be issued until ALL required inspections are approved.

#### 4. Processing of permit for approval

The Department of Permits & Inspections coordinates approvals by the following agencies as applicable:  
Washington County Health Dept.: To check for proper distance from private septic systems. (Not applicable when served by public sewer).  
Allegheny Power Co.: To check for the proper distance from existing electrical power lines.

#### 5. Underground work

Miss utility (1-800-257-7777) must be called to mark the property before **ANY** digging is to begin.

**NO WORK SHALL BE STARTED  
UNTIL THE PERMIT  
APPLICATION HAS BEEN  
APPROVED AND THE PERMIT  
ISSUED!**

A Use & Occupancy **CANNOT** be issued until **ALL** required inspections are approved.

**If the pool is used prior to the issuance of a Use and Occupancy Certificate, you may be subject to a civil citation, providing for a fine of One Hundred Dollars (\$100.00) per day from the date of the issuance of the citation.**

## Check List

### 1. Protective Barrier

**IRC Section AG105.2 Outdoor swimming pool.** An outdoor swimming pool, including an in-ground, above-ground or on-ground pool, hot tub or spa shall be surrounded by a barrier which shall comply with the following:

1. The top of the barrier shall be at least 48 inches (1219 mm) above *grade* measured on the side of the barrier which faces away from the swimming pool. The maximum vertical clearance between grade and the bottom of the barrier shall be 2 inches (51 mm) measured on the side of the barrier which faces away from the swimming pool. Where the top of the pool structure is above grade, such as an above-ground pool, the barrier may be at ground level, such as the pool structure, or mounted on top of the pool structure. Where the barrier is mounted on top of the pool structure, the maximum vertical clearance between the top of the pool structure and the bottom of the barrier shall be 4 inches (102 mm).
2. Openings in the barrier shall not allow passage of a 4-inch-diameter (102 mm) sphere.
3. Solid barriers which do not have openings, such as a masonry or stone wall, shall not contain indentations or protrusions except for normal construction tolerances and tooled masonry joints.
4. Where the barrier is composed of horizontal and vertical members and the distance between the tops of the horizontal members is less than 45 inches (1143 mm), the horizontal members shall be located on the swimming pool side of the fence. Spacing between vertical members shall not exceed 1<sup>3</sup>/<sub>4</sub> inches (44 mm) in width. Where there are decorative cutouts within vertical members, spacing within the cutouts shall not exceed 1<sup>3</sup>/<sub>4</sub> inches (44 mm) in width.

### 5. GFI Protection

Ground Fault Interrupter is required on all electrical equipment, motors, pumps, receptacles, lights, etc., serving the pool or located in close proximity of the pool. NEC Sections 680.22 / 218.8

#### **What is a ground fault?**

A ground Fault is any such fault current that is not strong enough to operate regular fuses or circuit breakers. A Ground Fault Interrupter detects small ground fault currents and cuts-off the circuit

A GROUND FAULT OF ONLY 60/1000 OF AN AMPERE PASSING THROUGH THE CHEST OF A HEALTHY ADULT CAN KILL HIM IN ONE SECOND. (THIS IS THE AMOUNT OF CURRENT USED BY A 7 1/2 WATT CHRISTMAS BULB). CHILDREN AND ADULTS IN POOR HEALTH MAY BE KILLED BY LESS.

#### **OTHER SAFETY MEASURES**

In addition to using GFI's there are other safety measures you can take to protect people using your pool or working near. Here are a few.

- \* Users of the pool should be warned against handling radios, barbecues, etc., while wet or while standing on concrete, earth, grass or wood (wet or dry).
- \* The use of portable appliances within 10 foot of the pool should be prohibited. (The National Electrical Code Forbids installation of outlets within 10 foot also).
- \* Do not run overhead wires across the pool or within 10 foot of it.
- \* Don't let extension cords run close to the pool.
- \* Always supervise young children in the pool area.
- \* Immediately let go of any electrical equipment that causes a tingling sensation when it or metal near it is touched. Disconnect it and have it repaired.
- \* If a portable radio connected to an outlet falls into the water, a fault current is capable of electrocuting a bather can occur even if the radio isn't turned on.

In-ground pool light Junction boxes shall be at least 4' from the waters edge and 8" above the maximum water level (NEC Section 680.24). It must be supported by at least 1 rigid pipe. (NEC Section 352.12)

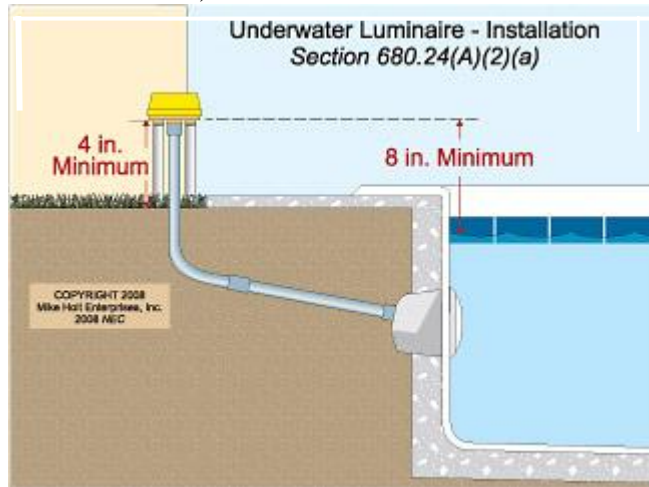

#### 4. Bonding

a. A # 8 solid bond must be run from the metal pool frame to the pump motor, water, accessories, and any other metal parts within 5 foot of the pool. NEC Section 680.26

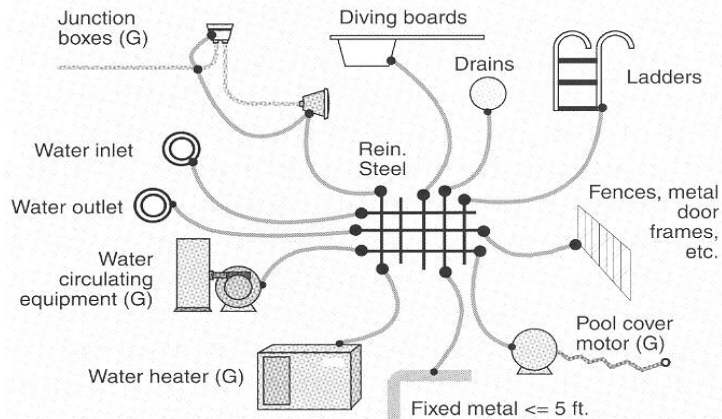

"G" = Also required to be grounded  
 Common bonding grid permitted to be:

- structural reinforcing steel rods that are bonded together
- wall of bolted or welded metal pool
- solid copper conductor No. 8 or larger

5. Where the barrier is composed of horizontal and vertical members and the distance between the tops of the horizontal members is 45 inches (1143 mm) or more, spacing between vertical members shall not exceed 4 inches (102 mm). Where there are decorative cutouts within vertical members, spacing within the cutouts shall not exceed 1<sup>3</sup>/<sub>4</sub> inches (44 mm) in width.

6. Maximum mesh size for chain link fences shall be a 2<sup>1</sup>/<sub>4</sub>-inch (57 mm) square unless the fence has slats fastened at the top or the bottom which reduce the openings to not more than 1<sup>3</sup>/<sub>4</sub> inches (44 mm).

7. Where the barrier is composed of diagonal members, such as a lattice fence, the maximum opening formed by the diagonal members shall not be more than 1<sup>3</sup>/<sub>4</sub> inches (44 mm).

8. Access gates shall comply with the requirements of [Section AG105.2](#), Items 1 through 7, and shall be equipped to accommodate a locking device. Pedestrian access gates shall open outward away from the pool and shall be self-closing and have a self-latching device. Gates other than pedestrian access gates shall have a self-latching device. Where the release mechanism of the self-latching device is located less than 54 inches (1372 mm) from the bottom of the gate, the release mechanism and openings shall comply with the following:

8.1. The release mechanism shall be located on the pool side of the gate at least 3 inches (76 mm) below the top of the gate; and

8.2. The gate and barrier shall have no opening larger than 1/2 inch (12.7 mm) within 18 inches (457 mm) of the release mechanism.

9. Where a wall of a *dwelling* serves as part of the barrier, one of the following conditions shall be met:

9.1. The pool shall be equipped with a powered safety cover in compliance with ASTM F 1346; or

9.2. Doors with direct access to the pool through that wall shall be equipped with an alarm which produces an audible warning when the door and/or its screen, if present, are opened. The alarm shall be listed and *labeled* in accordance with UL 2017. The deactivation switch(es) shall be located at least 54 inches (1372 mm) above the threshold of the door; or

10. Where an Aboveground Pool structure is used as a barrier or where the barrier is mounted on top of the pool structure and the means of access is a ladder or steps, then:

10.1. The ladder or steps shall be capable of being secured, locked or removed to prevent access; or

10.2. The ladder or steps shall be surrounded by a barrier which meets the requirements of [Section AG105.2](#), Items 1 through 9. When the ladder or steps are secured, locked or removed, any opening created shall not allow the passage of a 4-inch-diameter (102 mm) sphere

### 3. Wiring Underground

- a. All under ground piping shall be 18 inches deep to the top of the pipe. If the line is 120 volts or less & GFI protected then the pipe may be 12 inches deep for a residential pool. NEC Section 300.5
- b. Any line for a sub panel that services a pool shall be conduit the entire length of the run to the main panel with a 4-wire feed. NEC Section 680.25
- c. All trenches shall be left open for inspection.
- d. Caution tape shall be placed in the top 6 inches of the trench. IECCEC Section 702.1.3
- e. All under ground piping not related to the pool is to be at least 5 foot from the pool. NEC Section 680.10

### NEC 300.5 Minimum Burial Depth

Wiring Method	Minimum Burial (in.)
Rigid metal conduit	6
Intermediate metal conduit	6
Nonmetallic raceway (PVC)	18

2” of concrete encasement maybe used if SOLID rock is encountered



Typical pool light Junction box

# ELECTRICAL REQUIREMENTS FOR POOLS

## 1. Receptacle Placement

- There shall be No receptacle within 6 foot of the pool. Any pump receptacle located between 6 foot and 10 foot shall be a twist lock single receptacle with GFI protection. NEC Section 680.22
- There shall also be at least 1 GFI protected convenience receptacle located no closer than 6 foot but not more than 20 foot from the pool. NEC Section 680.22
- All outside receptacles shall be supported by a 4 x 4 post or Equivalent. NEC Section 352.12
- All outside receptacles shall have “in use” covers and be of the “Weather-Resistant” type. NEC Section 406.8

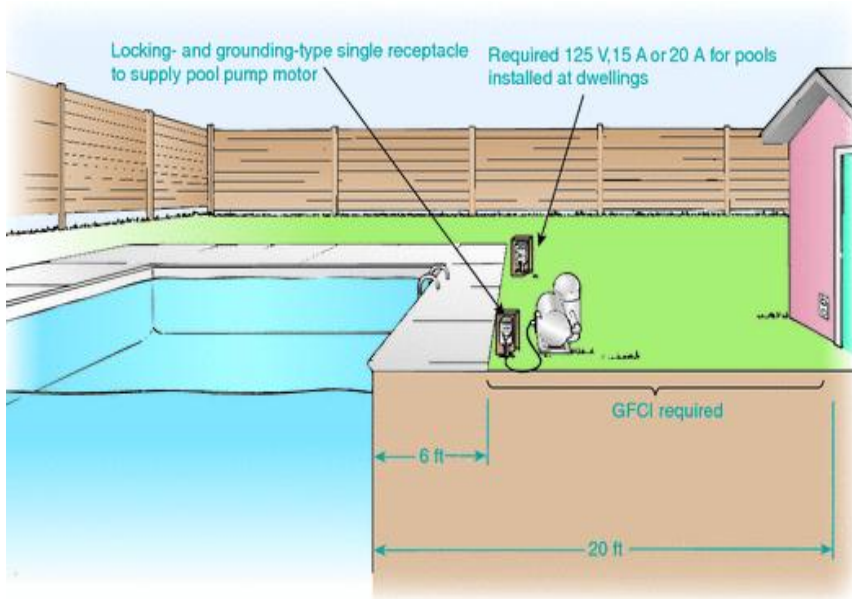

## 2. Pool pump and accessories

- Pool pump and accessories shall be at least 3 foot from the pool and GFI protected. NEC Section 680.22
- Cord for the pool pump shall be no longer than 3 foot with a #12 ground. NEC Section 680.21

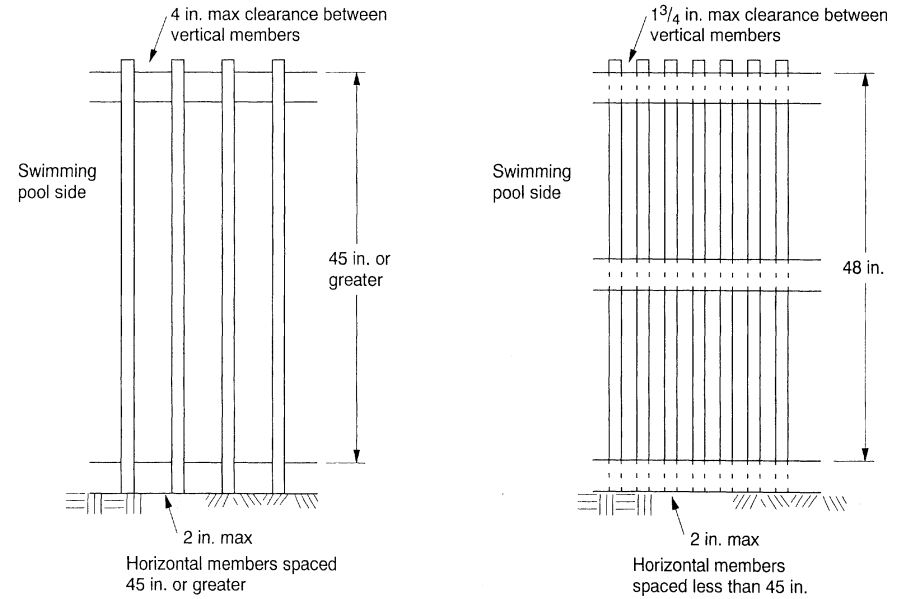

Figure AG105.2(2)  
PRIVATE SWIMMING POOL BARRIER CONSTRUCTION

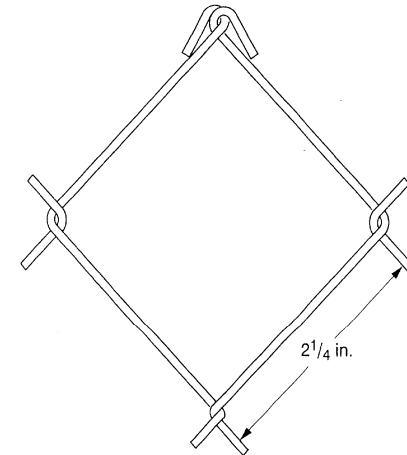

Figure AG105.2(3)  
CHAIN-LINK FENCE MESH FOR PRIVATE SWIMMING POOLS

**AG105.3 Indoor swimming pool.** Walls surrounding an indoor swimming pool shall comply with [Section AG105.2](#), Item 9.

**AG105.4 Prohibited locations.** Barriers shall be located to prohibit permanent structures, *equipment* or similar objects from being used to climb them.

**AG105.5 Barrier exceptions.** Spas or hot tubs with a safety cover which complies with ASTM F 1346, as listed in [Section AG107](#), shall be exempt from the provisions of this appendix.

**NOTE-** A barrier must be installed before **ANY** water is in the pool. Above ground pools need to maintain a 48" barrier, this may require the grade to be cut down to a distance of 3' from the edge of the pool. No pool equipment shall be set within 3' of an above ground pool in order to maintain the barrier requirements.

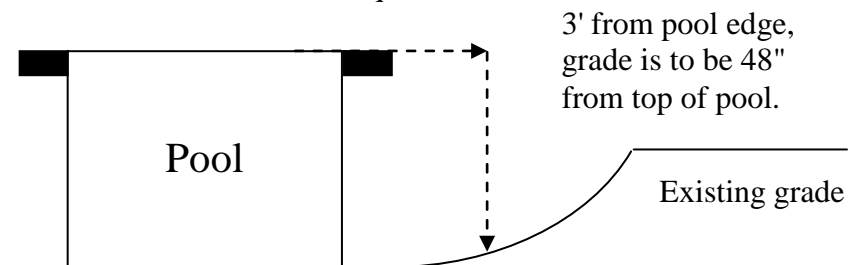

Above Ground Pool Grading Requirements.

## **2. Private Septic System:**

A swimming pool must not be placed within the 10,000 square foot area reserved for the septic system repair without the approval of the Washington County Health Department.

## **3. Private Water Supply:**

A swimming pool must be placed a safe distance from any well or private water supply on the property and is subject to the Washington County Health Department's approval.

## **4. Pool Water Supply:**

Any water supply line that could be used to fill a pool (pump connection, outdoor faucet, etc.) must be equipped with a vacuum breaker to prevent back flow from the pool into the water system and possible contamination of the drinking water.

## **5. Overhead Electrical Wires:**

A pool must not be placed under electrical power lines or service lines. Safe distances from the pool to any electrical wiring and equipment must be maintained as prescribed by the National Electrical Code. Proper clearances must be checked and approved by the Building and electrical inspectors and the power company. NEC Section 680.8

## **6. Bonding:**

All metal parts of the pool structure including the concrete reinforcing metal of the pool shell, coping, decks, forming shells, metal fittings, ladders, diving boards, light fixtures, electrical equipment, metal piping, conduits and the water it's self must be bonded together. Inspection is required before any item is covered. NEC Section 680.26

## **7. Energy Conservation**

All pool heaters are required to have a switch so that they can be turned off with out resetting the thermostat. IECC 403.9.1. All Pool pumps and heaters shall be equipped with a timer ether built in to the equipment or hardwired. IECC 403.9.2. All heated pools shall have a vapor-retardant pool cover and pools heated more than 90 degrees shall have a cover with a minimum insulation of R-12. IECC 403.9.3.